

# KONFORT 744



Rev.

**TEXA**





# SUMMARY

REVISION OF THE MANUAL.....	7
INTRODUCTION.....	8
1 LEGEND OF THE SYMBOLS USED.....	9
2 GENERAL SAFETY REGULATIONS.....	10
2.1 Glossary.....	10
2.2 Operator Safety Regulations.....	10
2.2.1 General Safety Regulations.....	10
2.2.2 Risk of Asphyxiation.....	10
2.2.3 Risk of Impact and Crushing.....	10
2.2.4 Hazards Caused by Moving Parts.....	11
2.2.5 Risk of Burning or Scalding.....	11
2.2.6 Fire and Explosion Hazard.....	12
2.2.7 Noise Hazard.....	12
2.2.8 High Voltage Hazard.....	12
2.2.9 Poisoning Hazard.....	13
2.3 General User and Maintenance Warnings.....	13
3 KONFORT 744 USER SAFETY.....	14
3.1 Glossary.....	14
3.2 General Rules.....	14
3.3 Operator Safety.....	15
3.4 Device Safety.....	15
3.5 Workplace Safety.....	16
3.6 Guidelines for the handling the refrigerants and user safety.....	16
3.7 Safety Devices.....	17
4 ENVIRONMENTAL INFORMATION.....	18
5 NORMATIVE INFORMATION.....	19
6 OPERATION OF THE TOOL'S RADIO DEVICES.....	20
7 KONFORT 744 RECHARGING STATIONS.....	21
8 DESCRIPTION.....	23
8.1 Front view.....	23

8.1.1	Top panel.....	24
8.2	Right Side View.....	24
8.3	Rear view.....	25
8.3.1	Containers.....	26
8.4	Left Side View.....	26
9	INSTALLATION.....	27
9.1	Unwrapping the Device.....	27
10	SETTING UP BEFORE USING.....	28
10.1	Scale Locking/unlocking.....	28
10.2	Refrigerant tank housing.....	28
10.3	Moving the Device.....	34
10.4	Positioning.....	35
10.5	Connection to the Power Mains.....	35
10.6	Entering the SD CARD.....	35
10.7	How to Load the Paper into the Printer.....	36
10.8	How to Fill the Bottles.....	36
10.9	Language Setup.....	37
11	START-UP.....	39
11.1	Switching on.....	39
11.2	Activation.....	39
12	User Instructions.....	40
12.1	How to Connect to the Vehicle Air Conditioning System.....	40
12.2	Visual Warnings.....	40
12.3	Audible Warnings.....	40
12.4	CO2 alarm.....	40
12.5	How to Use the Software .....	41
12.6	Printer.....	42
13	STOP.....	44
13.1	Normal Stop.....	44
13.2	Emergency Stop.....	44
13.3	Stopping the Equipment for Long Periods.....	44
14	UPDATING.....	45

<b>15</b>	<b>MAINTENANCE AND CLEANING</b> .....	<b>47</b>
<b>15.1</b>	<b>Ordinary Maintenance</b> .....	<b>47</b>
<b>15.1.1</b>	<b>How to Replace the Vacuum Pump Oil</b> .....	<b>48</b>
<b>15.1.2</b>	<b>Replacing the Paper in the Printer</b> .....	<b>48</b>
<b>15.2</b>	<b>Periodical Checks</b> .....	<b>49</b>
<b>16</b>	<b>DISPOSAL</b> .....	<b>51</b>
<b>16.1</b>	<b>How to Dispose of the Device</b> .....	<b>51</b>
<b>16.2</b>	<b>How to Dispose of the Recycled Materials</b> .....	<b>51</b>
<b>17</b>	<b>TECHNICAL FEATURES</b> .....	<b>52</b>
<b>18</b>	<b>TANK SPECIFICATIONS</b> .....	<b>54</b>
<b>19</b>	<b>LEGAL NOTICES</b> .....	<b>56</b>



# KONFORT 744 RECHARGING AND MAINTENANCE STATIONS TECHNICAL MANUAL

## **REVISION OF THE MANUAL**

This document is **review 01** of the technical manual for the **KONFORT 744** charging stations.

**Issue date:** 10/09/2019

# INTRODUCTION

Dear Customer,

We would like to thank you for choosing a TEXA product for your workshop.

We are certain that you will get the greatest satisfaction from it and receive a great deal of help in your work.

Please read through the instructions in this manual carefully and keep it for future reference.

Reading and understanding the following manual will help you to avoid damage or personal injury caused by improper use of the product to which it refers.

TEXA S.p.A reserves the right to make any changes deemed necessary to improve the manual for any technical or marketing requirement; the company may do so at any time without prior notice.

This product is intended for use by technicians specialized in the automotive field only. Reading and understanding the information in this manual cannot replace adequate specialized training in this field.

The sole purpose of the manual is to illustrate the operation of the product sold. It is not intended to offer technical training of any kind and technicians will therefore carry out any action under their own responsibility and will be accountable for any damage or personal injury caused by negligence, carelessness, or inexperience, regardless of the fact that a TEXA S.p.A. tool was used for the actions based on the information within this manual.

Any additions to this manual, useful in describing the new versions of the program and new functions associated to it, may be sent to you through our TEXA technical bulletin service.

This manual should be considered an integral part of the product to which it refers. In the case it is resold the original buyer is therefore required to forward the manual to the new owner.













Reproduction, whole or in part, of this manual in any form whatsoever without written authorization from the producer is strictly forbidden.

The original manual was written in Italian, every other language is a translation of the original manual.

© **copyright and database rights 2016.** The material contained in this document is protected by copyright and database rights. All rights reserved according to law and international agreements.

# 1 LEGEND OF THE SYMBOLS USED

The symbols used in the manual are described in this chapter.

	Asphyxiation Risk
	Explosion Risk
	High Voltage Hazard
	Fire / Burn risk
	Poisoning Hazard
	Corrosive Substances Risk
	Noise Hazard
	Moving Parts Risk
	Crushing Risk
	Risk of Stumbling
	Laser Radiation Hazard
	General Risk
	Important information

## 2 GENERAL SAFETY REGULATIONS

### 2.1 Glossary

- **Operator:** *qualified individual, in charge of using the device/tool.*
- **Machine/device/tool:** *the product purchased.*
- **Workplace:** *the place where the operator must carry out her/his work.*

### 2.2 Operator Safety Regulations

#### 2.2.1 General Safety Regulations

- *The operator must be completely clear-headed and sober when using the device; taking drugs or alcohol before or when operating the device is strictly forbidden.*
- *The operator must not smoke during device operation.*
- *The operator must carefully read all the information and instructions in the technical documents provided with the device.*
- *The operator must follow all the instructions provided in the technical documents.*
- *The operator must always watch over the device during the various operating phases.*
- *The operator must make sure she/he is working in environment which is suitable for the operations that must be carried out.*
- *The operator must report any faults or potentially hazardous situation in connection with the workplace or the device.*
- *The operator must carefully follow the safety regulations required for the workplace in which she/he is working and required by the operations she/he has been asked to carry out.*

#### 2.2.2 Risk of Asphyxiation

	Exhaust gas from internal combustion engines, whether they may be petrol or diesel, are hazardous to your health and can cause serious harm to your body.
---	---

#### Safety Precautions:

- *The workplace must be equipped with an adequate ventilation and air extraction system and must be in compliance with standards according to current national laws.*
- *Always activate the air extraction system when working in closed environments.*

#### 2.2.3 Risk of Impact and Crushing

	The vehicles which are undergoing A/C system recharging operations and the devices, must be properly blocked using the specific mechanical brakes/blocks, while being service.
---	--

## Safety Precautions:

- *Always make sure that the vehicle is in neutral gear (or that it is set in parking position in case of a vehicle equipped with automatic transmission).*
- *Always activate the hand brake or parking brake on the vehicle.*
- *Always block the wheels on the vehicle with the specific mechanical blocks.*
- *Make sure the device is stable, on a flat surface and the wheels are locked with the specific brakes.*



### 2.2.4 Hazards Caused by Moving Parts

	<p>Vehicle engines include parts that move, both while running and not running (eg: the cooling fan is controlled by a thermal switch in connection with the coolant temperature and become activated even when the vehicle is off), that can injure the operator.</p>
---	--

## Safety Precautions:

- *Keep hands away from moving parts.*
- *Disconnect the engine cooling fan each time the engine you are working on is still hot. This will avoid the fan from becoming activated unexpectedly even when the engine is off.*
- *Do not wear ties, loose clothes, wrist jewellery or watches when working on a vehicle.*
- *Keep connection cables, probes and similar devices away from the moving parts of the engine.*

### 2.2.5 Risk of Burning or Scalding

 	<p>The parts that are exposed to high temperatures in engines that are moving or have just stopped could burn the operator.</p> <p>Remember that catalytic mufflers reach very high temperatures, able to cause serious burns or even start fires.</p> <p>Acid in the vehicle batteries is another potential hazard.</p>
--	--

## Safety Precautions:

- *Protect your face, hands, and feet by using suitable protection.*
- *Avoid contact with hot surfaces, such as spark plugs, exhaust pipes, radiators and connections within the cooling system.*
- *Make sure there are no oil stains, rags, paper or other inflammable material near the muffler.*
- *Avoid splashing electrolyte on skin, eyes and clothes, as it is a corrosive and highly toxic compound.*

### 2.2.6 Fire and Explosion Hazard

	<p>The following are potential fires and/or explosion hazards:</p> <ul style="list-style-type: none"><li>• <i>The types of fuel used by the vehicle and the vapours released by these fuels.</i></li><li>• <i>The refrigerants used by the A/C system.</i></li><li>• <i>The acid in the vehicle batteries.</i></li></ul>
---	--

#### **Safety Precautions:**

- *Let the engine cool.*
- *Do NOT smoke near the vehicle.*
- *Do NOT expose the vehicle to open flames.*
- *Make sure that the electrical connections are all well insulated.*
- *Collect any fuel that might have spilled.*
- *Collect any refrigerant that might have spilled.*
- *Make sure you are always working in an environment equipped with a good ventilation and air extraction system.*
- *Always activate the air extraction system when working in closed environments.*
- *Cover the openings of the batteries with a wet cloth in order to stifle the explosive gases before proceeding in testing or recharging.*
- *Avoid causing sparks when connecting cables to the battery.*

### 2.2.7 Noise Hazard

	<p>Loud noises that may occur within the workplace, especially during service operations may damage the operator's hearing.</p>
---	---

#### **Safety Precautions:**

- *Protect your ears with suitable protective ear wear.*

### 2.2.8 High Voltage Hazard

	<p>The voltage supply from the mains that powers the devices in the workplace and the voltage within the vehicle starter system is a potential shock hazard to the operator.</p>
---	--

#### **Safety Precautions:**

- *Make sure the electrical system in the workplace is compliant to current national standards.*
- *Make sure the device being used is connected to ground.*
- *Cut off the power supply voltage before connecting or disconnecting cables.*
- *Do NOT touch the high voltage cables when the engine is on.*

- *Operate in conditions of insulation from ground.*
- *Work with dry hands only.*
- *Keep conductive liquids away from the engine while working.*
- *Never leave tools on the battery in order to avoid accidental contacts.*

### 2.2.9 Poisoning Hazard

	The hoses used to extract the refrigerants can release toxic gases, dangerous to the operator if exposed to temperatures higher than 250 °C or in case of a fire.
---	---

#### **Safety Precautions:**

- *Contact a doctor immediately should you inhale these gases.*
- *Use neoprene or PVC gloves when eliminating combustion deposits.*

### 2.3 General User and Maintenance Warnings

When using the device or carrying out scheduled maintenance (eg. fuse replacement) on the device, carefully follow the information provided below.

- *Do not remove or damage the labels/tags and the warnings on the device; do NOT in any case make them illegible.*
- *Do not remove, or block, any safety devices the device is equipped with.*
- *Only use original spare parts or spare parts approved by the manufacturer.*
- *Contact your retailer for any non-scheduled maintenance.*
- *Periodically check the electrical connections of the device, making sure they are in good condition and replacing any damaged cables.*
- *Check parts that are subject to wear periodically and replace if necessary.*
- *Do not open or disassemble the device.*

## 3 KONFORT 744 USER SAFETY

Technology used for the design and testing of the recharging stations **KONFORT 744** make them simple, reliable and safe.

Personnel in charge of using the recharging stations is required to follow the general safety regulations, use the **KONFORT 744** recharging stations for their intended use only and carry out the maintenance as described in this manual.

TEXA S.p.A. declines any responsibility deriving from an improper use of this product that is not within its destination of use or an appropriate workspace or that does not meet the safety regulations and the procedure described here within.

### 3.1 Glossary

- **Equipment:** *any KONFORT 744 charging station (the charging station does not include the external refrigerant tank).*
- **External tank:** *new R744 (carbon dioxide, CO<sub>2</sub>) tank.*
- **Cycle:** *automatic execution of the single phases.*
- **Operating phase:** *a single operation carried out by the equipment (ex. Charge).*
- **UV tracer injection:** *the introduction of UV tracer into the A/C system in order to check for leaks.*
- **Oil injection:** *the introduction of oil into the A/C system in order to restore the correct quantity recommended by the manufacturer.*
- **Operator:** *qualified individual, in charge of servicing air conditioning systems using the KONFORT 744 recharging station.*
- **Refrigerant:** *R744 (carbon dioxide, CO<sub>2</sub>) coolant.*
- **Refilling:** *refrigerant charging phase; charges the A/C system with the quantity of refrigerant recommended by the manufacturer.*
- **Discharge:** *discharge of the refrigerant inside the A/C system.*
- **A/C system:** *air conditioning or climate control system.*
- **Vacuuming:** *the evacuation of incondensable gases and humidity from within the A/C system exclusively through a vacuum pump.*

### 3.2 General Rules

- *The operator must have basic knowledge of refrigeration, of the refrigeration system, of refrigerants and of the potential hazards that equipment under extreme pressure can cause.*
- *The operator must have fully read and understood the information and the instructions described in the technical documentation provided with the device.*
- *The equipment must be used only by personnel properly trained by TEXA S.p.A. or through courses that are specifically approved by TEXA S.p.A.*

### 3.3 Operator Safety

The use of refrigerants may cause serious risks for your health.

Detailed medical and safety information can be obtained from the manufacturers of the lubricants and refrigerants.

#### **SUFFOCATION**

Inhaling large amounts of R744 (carbon dioxide, CO<sub>2</sub>) refrigerant may be harmful due to its low content of oxygen.

During the discharge, the R744 (carbon dioxide, CO<sub>2</sub>) refrigerant of the A/C system is released directly into the air, constantly checking the degree of concentration of carbon dioxide (CO<sub>2</sub>) in the working area thanks to a specific sensor.

Through both visible and audible indications, the equipment warns that an excessive level of concentration of carbon dioxide (CO<sub>2</sub>) has been reached and automatically interrupts the activity in progress.

The discharge of the refrigerant resumes normally once the alarm has ceased, when the level of carbon dioxide (CO<sub>2</sub>) has returned to normal.

#### **Safety Precautions:**

- *Use the equipment in well-ventilated environments only.*
- *Avoid inhaling the refrigerant; use appropriate safety devices when required.*
- *If the equipment, through the specific alarm, warns that there is high level of concentration of carbon dioxide (CO<sub>2</sub>), move away from it and aerate the workspace for the time needed in order to bring the level of concentration of carbon dioxide (CO<sub>2</sub>) back within the safety level.*

#### **FREEZING AND FREEZE BURNS**

Given their low condensation temperature, physical contact with the refrigerants may cause freeze burns.

#### **Safety Measures:**

- *Wear adequate safety glasses and gloves, that prevent direct contact with the refrigerants.*
- *Make sure the refrigerant tank's valve is closed before moving it.*
- *Make sure the service pipes are not under pressure before disconnecting them.*

#### **BLINDNESS**

Direct contact of the refrigerant with eyes may cause blindness.

#### **Safety measures:**

- *Wear protective goggles!*

### 3.4 Device Safety

- *Use R744 (carbon dioxide, CO<sub>2</sub>) refrigerant only.*

- *Make sure you use the correct refrigerant for the vehicle you are working on.*
- *Connect the hoses correctly by following the colours indicated: Blue hose - LP connection, red hose - HP connection.*
- *Make sure all the valves are closed before connecting the device to the A/C system or to an external cylinder.*
- *It is absolutely forbidden to modify the calibration of the safety valves and the control systems.*
- *Do not smoke near the device or during the operating phases.*
- *Do not use the equipment near open flames, sparks, hot surfaces: the refrigerant decomposes at high temperatures, letting off toxic chemical substances that may cause fires or explosions.*
- *Do not expose the device to direct sunlight, rain and bad weather conditions.*
- *Disconnect the hoses with extreme caution; they may contain refrigerant under high pressure.*
- *Do not leave the device connected to the power supply if you do not intend to use it immediately.*
- *To move the equipment use the specific handles only and balance the station on its wheels.*
- *If storing the device for a long period of time, disconnect it from the power mains and put it in a safe place, where it is not exposed to outside weather conditions.*

### **3.5 Workplace Safety**

The device is designed to work at a maximum altitude of 1000 m above sea level, with an operating temperature between 10°C and 50 °C and a maximum humidity of 50% at 50 °C.

#### **Safety measures:**

- *Never, under any circumstance, use the device in an environment where there is risk of an explosion.*
- *Only use the device in open or well-ventilated environments (at least 4 air changes per hour).*
- *Make sure the workplace is well-lit (average operating illuminance, for mechanic workshops and assembly on work benches for precision work, is 500-750-1000 lux).*

### **3.6 Guidelines for the handling the refrigerants and user safety**

The equipment has been designed and built to operate with R744 (carbon dioxide, CO<sub>2</sub>) refrigerant only.

#### **Safety measures:**

- *Do not transport the equipment with the external tank installed.*
- *The cylinders must be perfectly clean and clearly labelled in order to identify the refrigerant contained within.*
- *Use tanks with pickup pumps only.*

- *Do not use external tanks or other storage systems that have not been approved and/or that are not equipped with safety valves.*
- *Consult the safety sheet of this refrigerant in order to store it correctly.*
- *Store the refrigerant tanks in well-ventilated environments and away from sunlight.*
- *Before switching off the equipment, using the specific pressure gauges, make sure the service pipes are not under pressure and eventually depressurise them through the specific software function.*

### **3.7 Safety Devices**

The **KONFORT 744** recharging stations are equipped with the following safety features:

- **Emergency button:** *it allows you to cut off the power supply from the mains in case of emergency or in order to carry out maintenance operations.*
- **Rupture discs:** *rupture discs are membranes that are calibrated to open at 200 bar  $\pm$  10% needed to protect the equipment's hydraulic circuit areas. When one or more rupture discs intervene, the equipment can no longer be used until the discs are replaced by authorised and qualified personnel.*

**Tampering with the above mentioned safety devices of any kind is strictly forbidden.**

## 4 ENVIRONMENTAL INFORMATION



Do not dispose of this product with other undifferentiated solid waste.  
For information regarding the disposal of this product please see the pamphlet supplied.

## 5 NORMATIVE INFORMATION

### Simplified EU Declaration of Conformity

	<p>The manufacturer, TEXA S.p.A., declares that the type of <b>KONFORT 744</b> equipment complies with the following directives:</p> <ul style="list-style-type: none"><li>• <i>PED 2014/68/EU</i></li><li>• <i>Machinery directive 2006/42/EC</i></li><li>• <i>Low voltage directive 2014/35/EU</i></li><li>• <i>RED 2014/53/UE</i></li><li>• <i>RoHS 2011/65/EU</i></li></ul> <p>The complete text of the EU declaration of conformity is available at the following Internet address: <a href="http://www.texa.it/download">http://www.texa.it/download</a>.</p>
---	---

## **6 OPERATION OF THE TOOL'S RADIO DEVICES**

### **Wireless connection with Bluetooth, WiFi and HSUPA technology**

Wireless connectivity through Bluetooth, WiFi and HSUPA is a technology that supplies a standard, reliable method for exchanging information between different devices using radio waves. Many other products besides those built by TEXA use this technology, such as mobile phones, portable devices, Computers, printers, cameras, Pocket PCs etc.

The Bluetooth, WiFi and HSUPA interfaces search for compatible electronic devices based on the radio signals they emit and establish a connection. TEXA tools only select and prompt compatible TEXA devices. This does not exclude the presence of other sources of communication or disturbance.

THE EFFICIENCY AND QUALITY OF BLUETOOTH, WiFi AND HSUPA COMMUNICATION MAY BE AFFECTED BY THE PRESENCE OF RADIO DISTURBANCE. THE COMMUNICATION PROTOCOL IS DESIGNED TO MANAGE THESE TYPES OF ERRORS; HOWEVER, IN SUCH CASES COMMUNICATION MAY BE DIFFICULT AND CONNECTION MAY REQUIRE SEVERAL ATTEMPTS.

SHOULD THE WIRELESS CONNECTION ENCOUNTER SERIOUS PROBLEMS AND COMPROMISE REGULAR COMMUNICATION, THE SOURCE OF THE ENVIRONMENTAL ELECTROMAGNETIC DISTURBANCE MUST BE IDENTIFIED AND ITS INTENSITY REDUCED.

Position the tool so that the radio devices it is equipped with can work properly. In particular, do not cover it with any shielding or metallic materials in general.

## 7 KONFORT 744 RECHARGING STATIONS

The **KONFORT 744** charging stations are intended for the maintenance of A/C systems that use carbon dioxide as refrigerant.

The **KONFORT 744** stations are high performance devices capable of carrying out the following operations in complete safety: system discharge, vacuum, oil injection, UV dye injection, system charge and leak checks on A/C systems.

The **KONFORT 744** stations are provided with an **SD CARD** containing the dedicated software.

The **SD CARD** allows you to automatically store the data of each service carried out.

The software update can be performed through the **SD CARD**.

The **FORMING GAS KIT** for leak detection is available.

The **FORMING GAS KIT**, once connected to the equipment, allows you to test the A/C system under pressure in order to be able to detect possible leaks through a specific software function.



## MAIN FEATURES

- *R744 compatible*
- *High visibility TFT display*
- *Pressure gauge assembly Cl. 1.6*
- *Double stage vacuum pump*
- *2.5 mm service pipes*
- *Charging precision  $\pm 10$  g*
- *Anti-contamination airtight oil bottles (patent pending)*
- *High-precision oil injection*
- *Automatic oil bottle recognition (patent pending)*
- *Automatic measurement of discharged refrigerant*
- *Automatic check of concentration of CO2 into the atmosphere*
- *Refrigerant tank anti-shift system*
- *Thermal printer*
- *Automatic maintenance service management*
- *Multilingual coverage of the software*
- *Service hoses automatic length offset*
- *Automatic maintenance warning*
- *Operating mode:*
  - *CUSTOMIZED SERVICE*
  - *SYSTEM DISCHARGE*
  - *SYSTEM VACUUM*
  - *SYSTEM CHARGE*

## 8 DESCRIPTION

This chapter describes the general features of the charging stations. The images that follow show the charging station without the external refrigerant tank.

The installation of the external tank is illustrated in a specific chapter.

### 8.1 Front view



1. Top panel
2. Caster wheel
3. Body of the recharging station
4. Caster wheel

### 8.1.1 Top panel

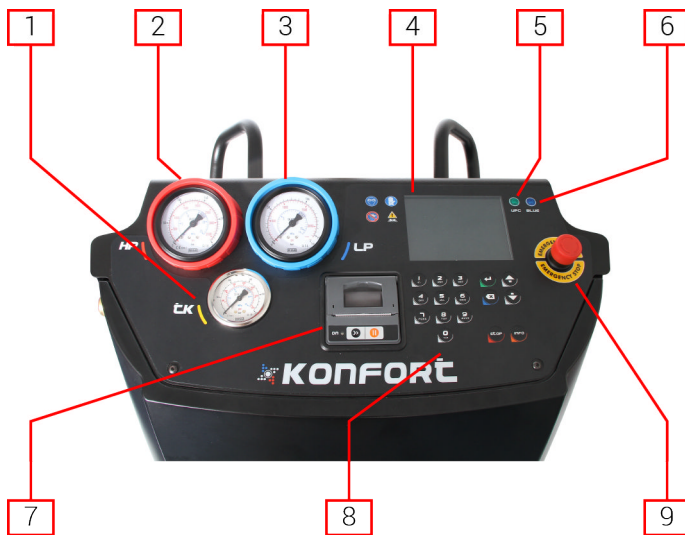

1. **TK** - Refrigerant tank pressure gauge
2. **HP** - High-pressure gauge
3. **LP** - Low-pressure gauge
4. High visibility TFT colour display
5. **UPG LED** - software upgrade
6. **BLUE LED** - Bluetooth communication
7. Thermal printer
8. Control keypad
9. Emergency button

### 8.2 Right Side View

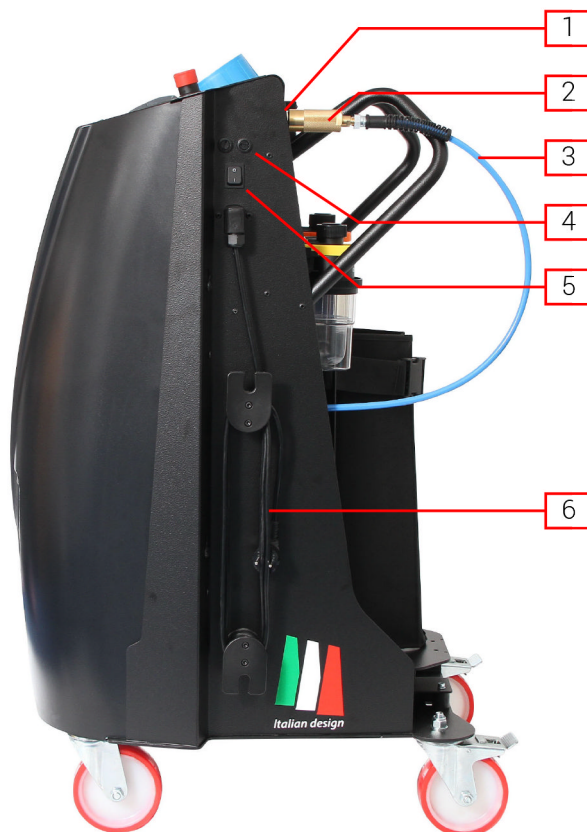

1. Tank hose resting support
2. Refrigerant tank coupler
3. Refrigerant tank hose
4. Safety fuses
5. Main switch
6. Power supply cable

## 8.3 Rear view

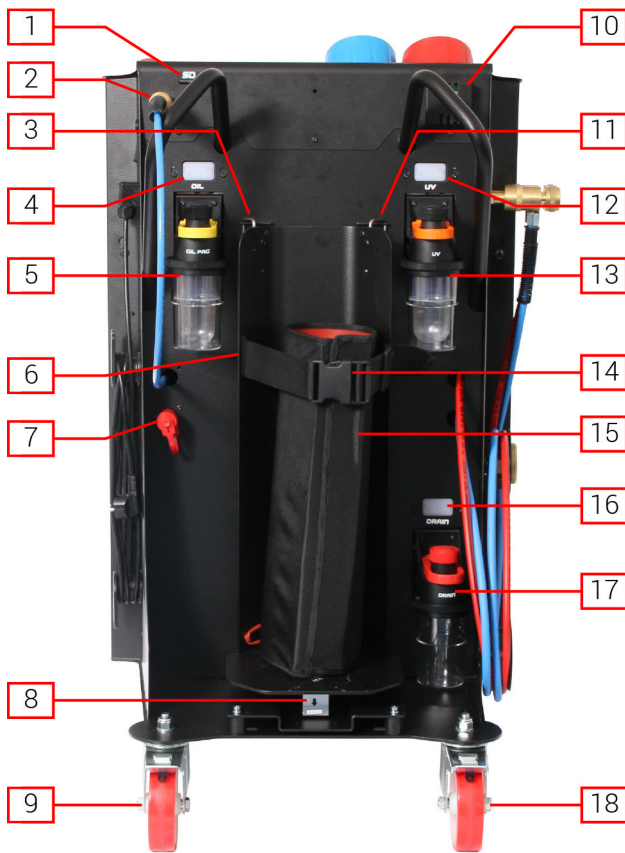

1. SD slot
2. Refrigerant tank coupler
3. Refrigerant tank anti-shift lock
4. **OIL** bottle status LED
5. **OIL PAG** air-tight bottle for specific oil
6. Refrigerant tank housing
7. **FORMING GAS KIT** coupler
8. Scale
9. Caster wheel with brakes
10. CO2 sensor
11. Refrigerant tank anti-shift lock
12. **UV** bottle status LED
13. **UV** air-tight bottle for UV tracer
14. Refrigerant tank locking belt
15. Band heater with magnets
16. **DRAIN** bottle status LED
17. **DRAIN** air-tight bottle to hold the oil that has been recovered
18. Caster wheel with brakes

For all the bottle status LEDs:

- **GREEN:** bottle inserted correctly
- **RED:** bottle removed or not correctly inserted.

### 8.3.1 Containers

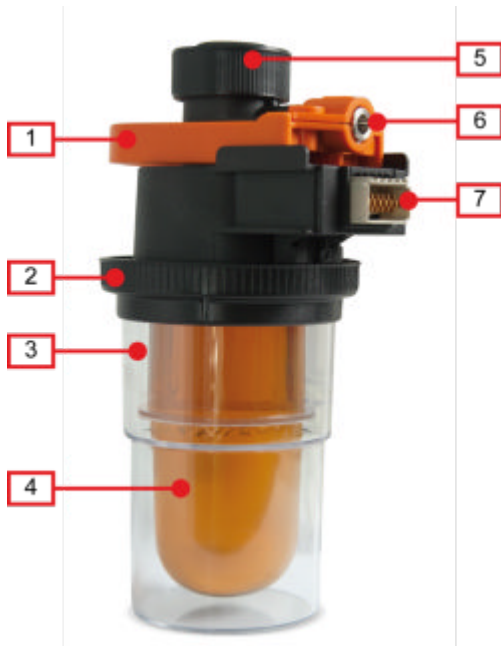

1. Bottle unlocking handle\*
2. Cup fastening ring
3. Cup
4. Tank\*\*
5. Tank cap
6. Pneumatic connection
7. Electronic connector

(\*) The colour of the unlocking handle indicates what the bottle must be used for.

(\*\*) not present in the **DRAIN** bottle

The colours correspond to the following uses:

- **Yellow:** PAG oil
- **Orange:** UV tracer
- **Red:** recovered oil

### 8.4 Left Side View

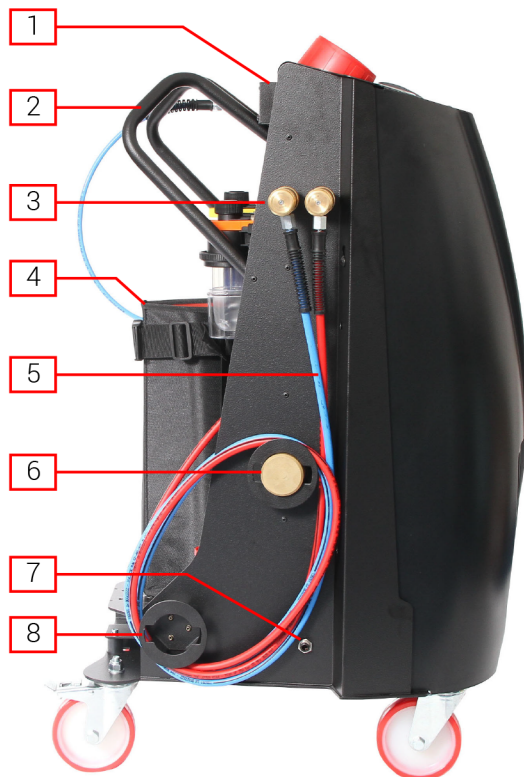

1. CO2 Sensor
2. Handles
3. LP and HP quick couplers
4. Band heater with magnets
5. Service hoses
6. Sample weight
7. Gas discharge
8. Hose holder

## 9 INSTALLATION

This chapter describes the procedures required in order to install the device properly.



**The installation must be performed by qualified personnel only, carefully following the instructions provided in this manual.**

The device is provided with the following:

- **Technical Manual:** *contains the description of the device, user instructions to guarantee a correct use and correct maintenance.*
- **CD Documentation:** *contains the technical and operating manual (user instructions for the device)*
- **SD CARD**
- **SD CARD READER**
- **Protective cover for the device**

### 9.1 Unwrapping the Device

This chapter describes the instructions for unwrapping/unpacking the device.



**Perform the described operations with extreme care and on a flat surface in order to avoid the device from tipping over.**

Proceed as follows:

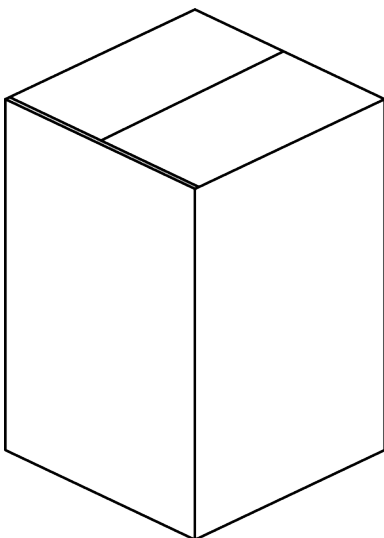

1. *Remove the cardboard.*
2. *Remove the bands that fasten the device to the pallet.*
3. *Remove the device from the pallet.*
4. *Unlock the wheels.*
5. *Make sure the device is in good condition and that it has not been tampered with and/or damaged.*
6. *Make sure no parts are missing.*

## 10 SETTING UP BEFORE USING

This chapter describes the maintenance operations required for setting up the equipment.

### 10.1 Scale Locking/unlocking

The equipment is fitted with a locking system for the electronic refrigerant scale. The refrigerant tank is locked by the specific anti-shift locks located on the rear side of the equipment.

The locks stabilise the refrigerant tank's housing avoiding it to shift while the equipment is being moved and they also lock the scale.



**You must always lock the scale before moving the equipment.**

Proceed as follows:

1. Go behind the equipment.
2. Locate the two anti-shift locks.
3. Lift the hooks from their housing.
4. Turn the hooks towards the refrigerant tank's housing.
5. Lower the hooks until firmly clasping the eyelets located on the refrigerant tank's housing.

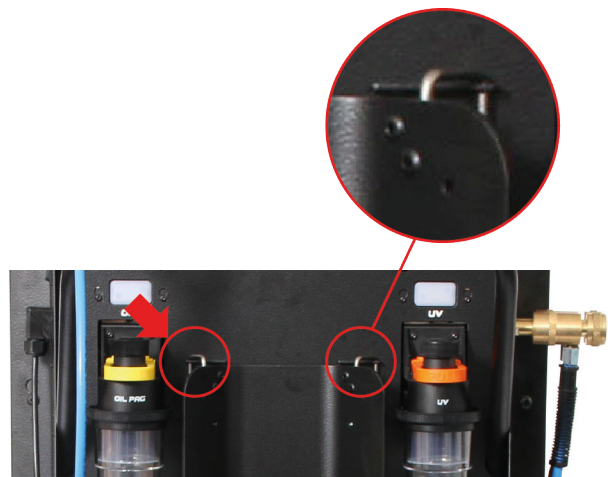

**If the scale is not unlocked removing the anti-shift locks, this may cause errors during the refrigerant charging phase.**

**Always unlock the scale before using the equipment.**

To unlock the scale, remove the anti-shift locks by carrying out the procedure described above backwards, from step 5 to step 3.

### 10.2 Refrigerant tank housing

The equipment is delivered without an external tank installed.

The external refrigerant tank must be placed in its specific housing and fastened to it.

To install the refrigerant tank correctly, other than positioning and connecting it properly, use the software's **TANK CHANGE** function.



**Only use tanks with pickup pumps with features in compliance with the indications in the Tank Specifications chapter.**



**Make sure the tank's valve is closed before proceeding with the operations indicated below.**



**Be careful while moving the tank, especially when lifting it and placing it in its housing.**

**If the operation is difficult (for example because the tank is heavy), ask for the help of other authorised personnel.**



**We recommend using a 10 kg refrigerant tank.**

Proceed as follows:

Go behind the equipment.

Block the rear caster wheels.

Locate the refrigerant tank's housing.

Open the refrigerant tank's locking belt.

Divide the band heater's magnets.



Stand in front of the equipment.

Press  until selecting **ADDITIONAL FUNCTIONS.**

Press .

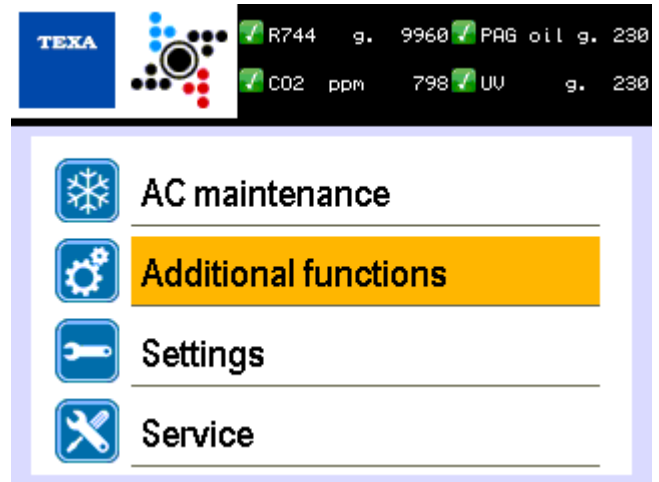

Press  until selecting **TANK CHANGE.**

Press .

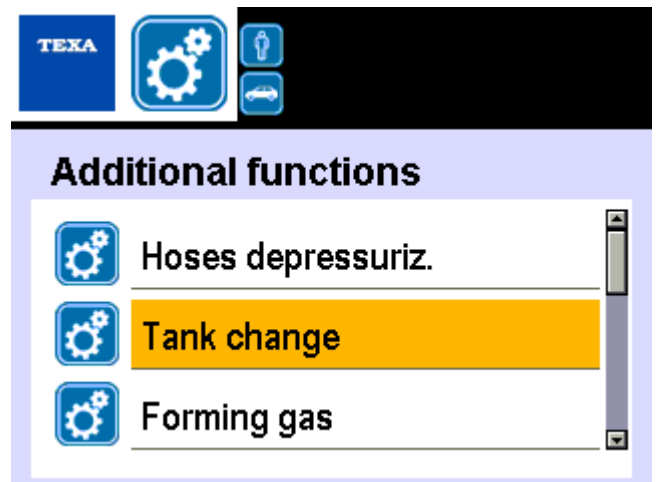

Make sure the tank's valve is closed.

Press .

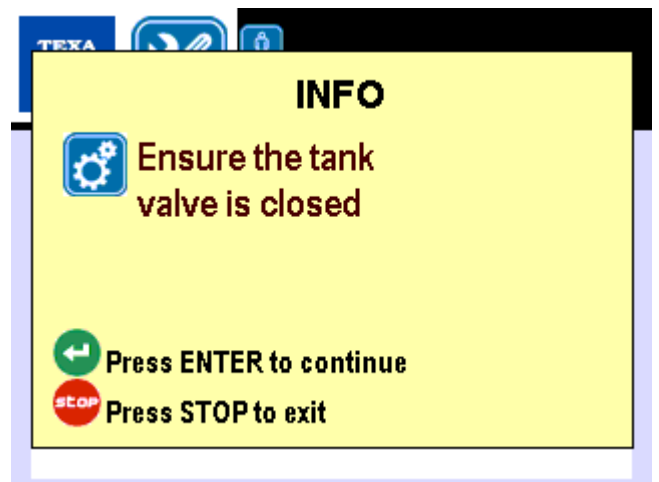

This step concerns replacing a tank, therefore it **must** be skipped.

Press .

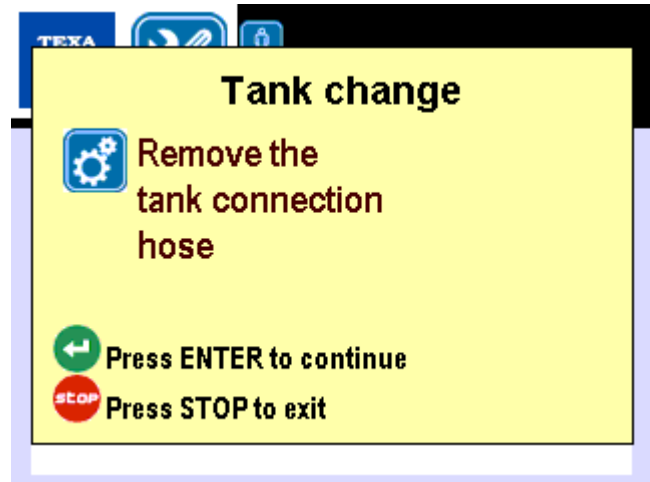

Place the tank in its housing.

Press .

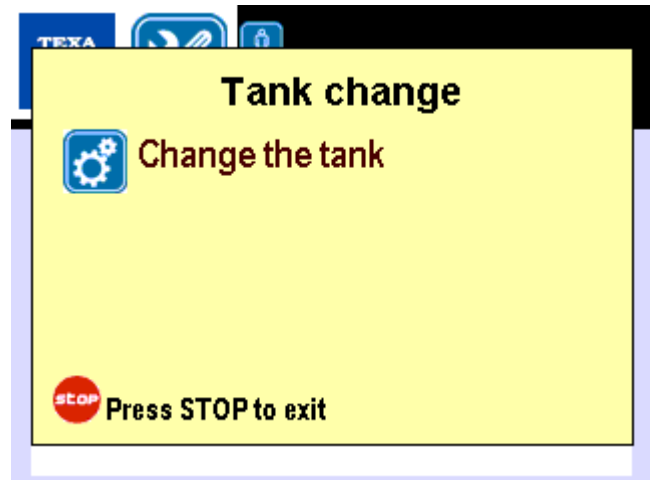

Apply the band heater's magnets to the tank so that the heater is well taut and the band touches the interested surface uniformly.

Close the locking belt so that the tank is firmly fastened to its housing.

Press .

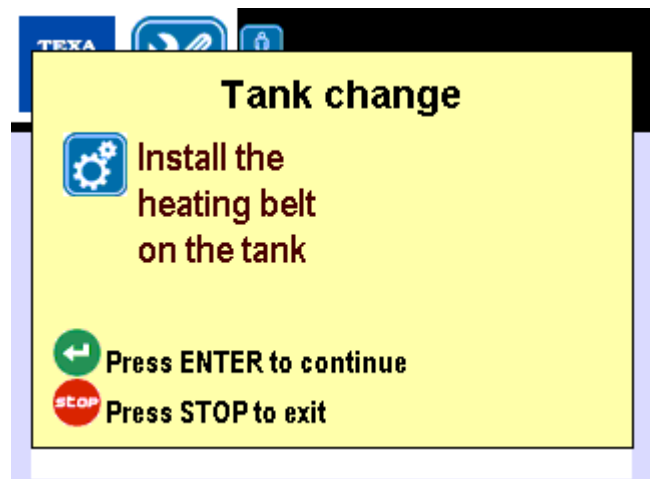

Remove the refrigerant tank hose from its resting support.  
Connect the refrigerant hose to the tank.

Press  .

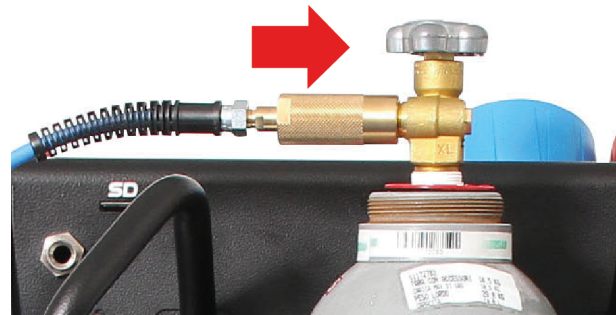
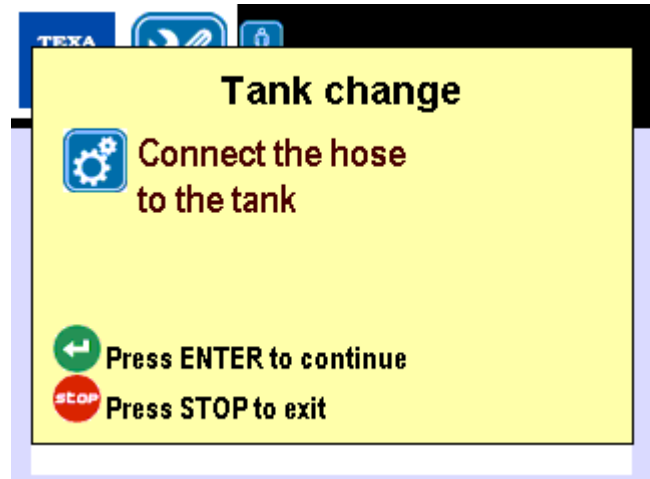

Remove the sample weight from its housing.  
Place the sample weight on the tank.

Press  .

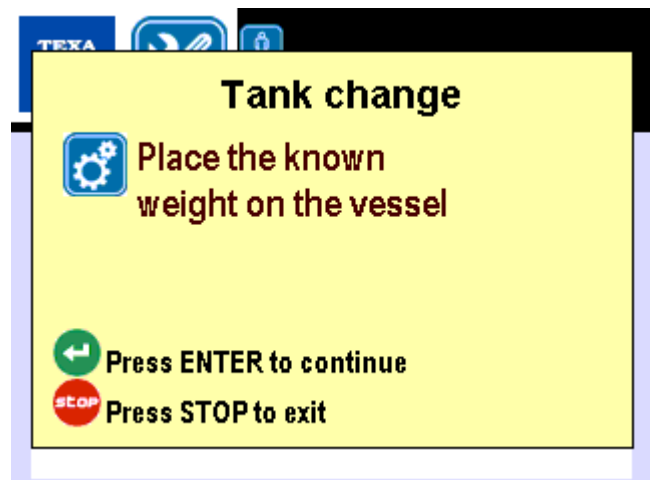

Enter the required data.

Press .

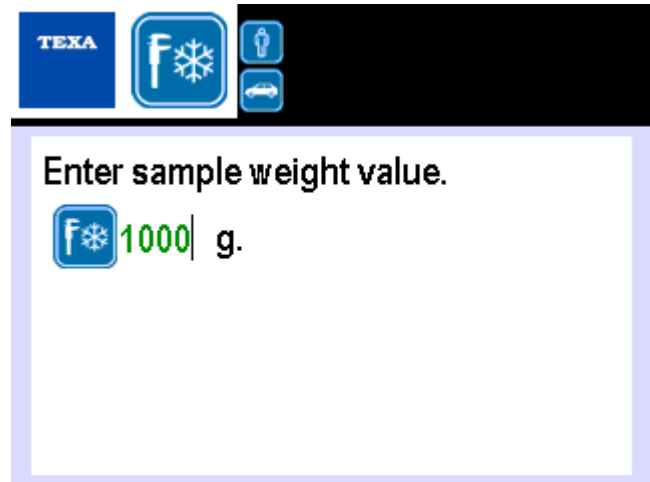

Remove the sample weight from the tank.

Put the sample weight back into its housing.

Press .

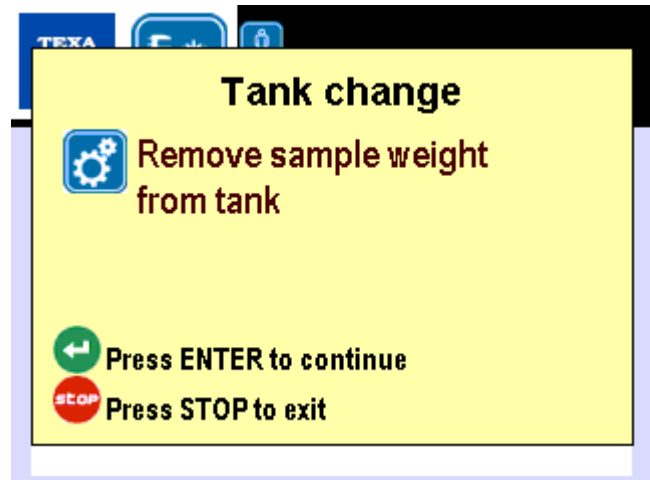

Open the tank's valve.

Press .

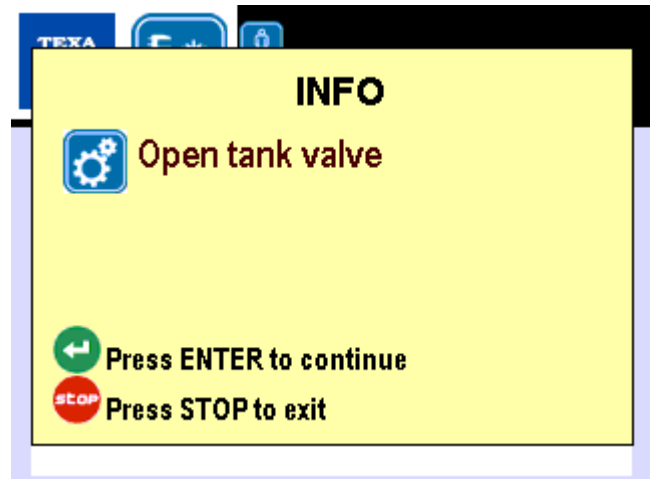

Enter the required data.

Press .

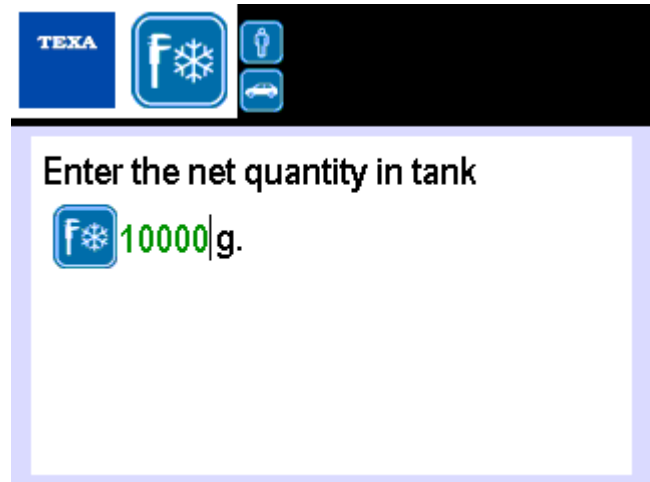

Press .

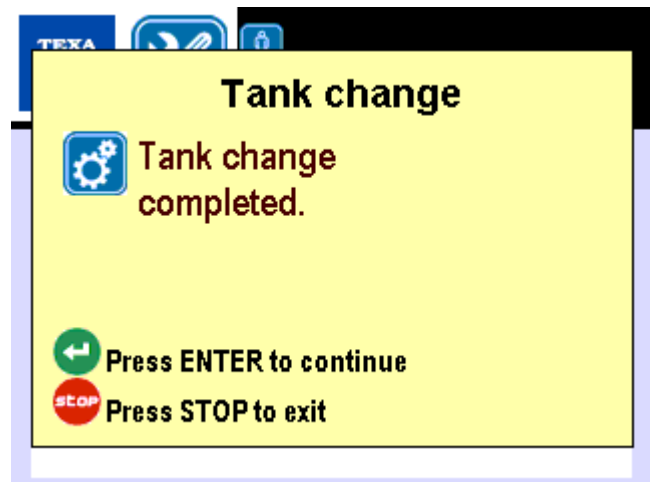

### 10.3 Moving the Device

The device has been specifically researched and designed to lower the centre of mass; to do so the heavier components have been placed on the bottom, nonetheless it wasn't possible to completely eliminate the risk of overturning. The equipment must be moved on its own wheels.



**The anti-shift locks must be used each time the equipment is moved within the workspace with the refrigerant tank installed.**

Proceed as follows:

1. *Lock the refrigerant scale.*
2. *Unlock the wheels (if necessary) and push the equipment using the specific handles located on the back of it.*



**The equipment must never be transported with the refrigerant tank still installed.**

**Remove the refrigerant tank even for short transportation and use the original packaging.**

## 10.4 Positioning

The device must be placed near the A/C system that must be checked; make sure it is on a flat surface and in an appropriate environment, as specified in the safety regulations within this manual.

Once the device has been positioned, we suggest locking the wheels with the specific mechanical brakes the wheels are equipped with.



**Position the equipment so that the main switch can be always reached easily.**

## 10.5 Connection to the Power Mains

The device must be connected to the mains via the specific supply cable; respect the applicable voltage, frequency and power values.

The voltage, frequency, and power values that can be applied can be found on the tag located near the main switch.

Proceed as follows:

1. *Go to the left hand side of the device.*
2. *Connect the supply cable to the power mains via a socket connected to ground.*

## 10.6 Entering the SD CARD

The **SD CARD** contains the software thanks to which the equipment can be started and carry out all the A/C system charging operations.

The software allows you to automatically store each charging service carried out.



**The SD CARD must be inserted into the specific slot before use,**

Proceed as follows:

1. Locate the **SD CARD** slot.
2. Enter the **SD CARD** in the slot with the label facing upwards until you hear a soft click.

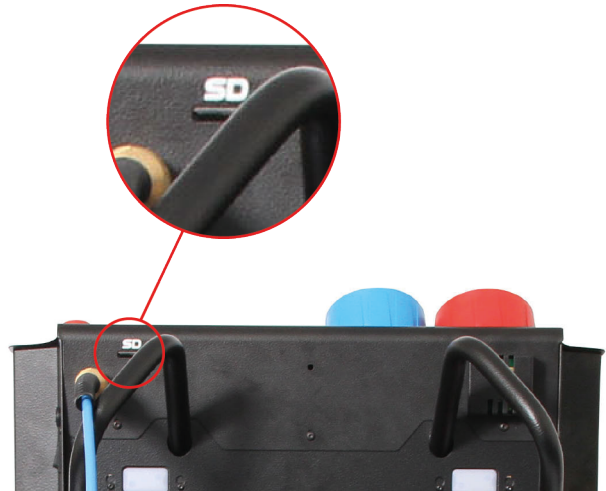

## 10.7 How to Load the Paper into the Printer

The equipment is provided with a thermal printer.



**You must fill the printer with paper before use.**

Proceed as follows:

1. Lift the paper compartment opening lever lightly until the corresponding cover locks.
2. Place the paper roll into the specific compartment.
3. Close the compartment pressing lightly on the cover and leaving a slip of paper sticking out.
4. Press  to make sure the paper has been inserted correctly.
5. Repeat the operations indicated above if the paper does not come out.

## 10.8 How to Fill the Bottles



**You must fill the oil and UV tracer bottles before use.**



**Fill the bottle with the correct type of oil.**

That bottles that are provided with the equipment are delivered empty and must be filled properly.

Proceed as follows:

1. Remove the bottle by pulling the unlocking handle.
2. Screw the tank cap off.
3. Fill the bottle with the oil/UV tracer.
4. Screw the tank cap on.

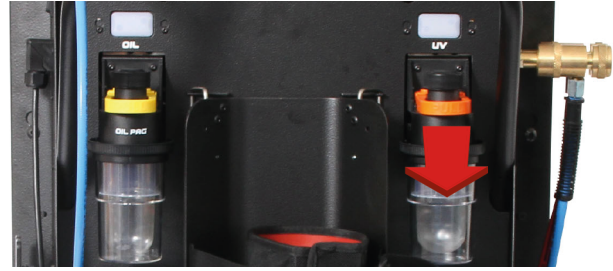

5. Reinsert the bottle.



The status LED indicates if the related bottle was inserted correctly:

- **GREEN:** *bottle inserted correctly*
- **RED:** *bottle removed or not correctly inserted.*

## 10.9 Language Setup

The software within the device can be viewed in different languages. The languages available are stored within the **SD CARD**. **Italian** is the default language.



**You must set the software's display language.**

This operation must be **carried out when the equipment is started for the first time**.

You may change the language selected at any time by following the instructions provided in this chapter.

The following procedure uses as examples screens displayed by the charging stations that are equipped with a TFT colour display.

Proceed as follows:

Turn on the equipment.

Press  until selecting **SETTINGS.**

Press  .

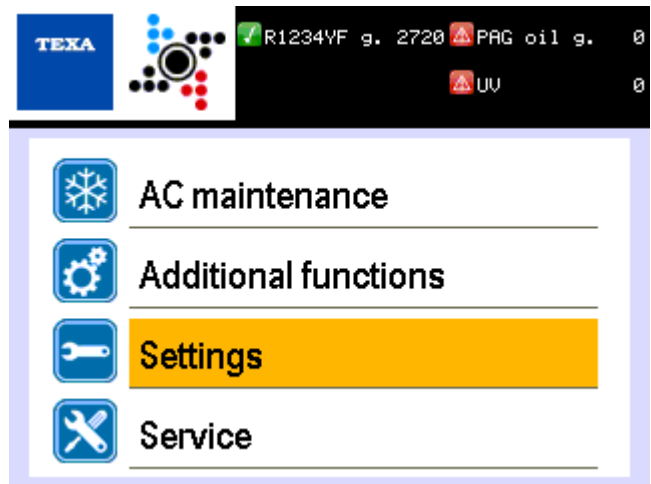

Press  until selecting **LANGUAGE.**

Press  .

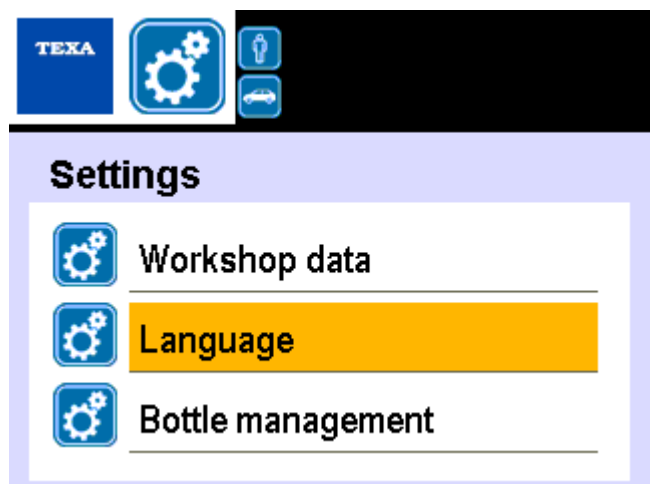

Press  until reaching the item that corresponds to the desired language.

Press  .

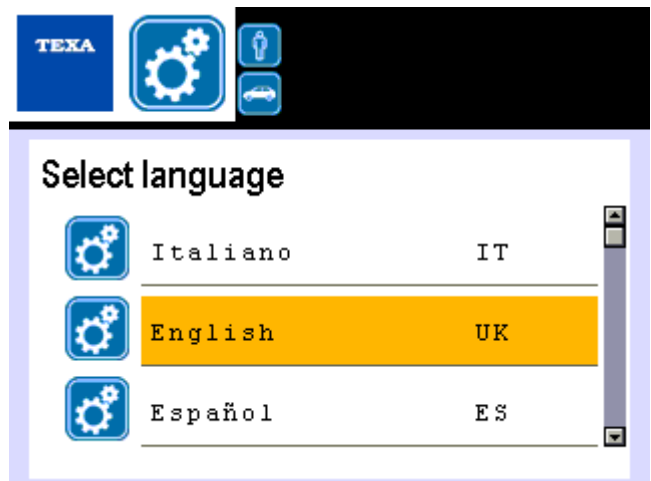

The language is set.

# 11 START-UP

This chapter describes the operations required in order to start up the device.

## 11.1 Switching on

To start up the device, set the main switch in the I (ON) position.

## 11.2 Activation

The device includes a demo mode (**Demo**).

The device can be used in **Demo** mode for a **maximum cycle of 15 power on-power offs**.



**The equipment locks automatically at the end of the cycle and can no longer be used.**



**In order to unlock the equipment you must enter a specific countercode.**

Proceed as follows:

1. Contact your dealer.
2. Give the retailer the code.
3. Enter the counter-code into the software.

## 12 User Instructions

This chapter provides various general instructions on how to use the device.  
**For further information consult the software's Operating Manual.**

### 12.1 How to Connect to the Vehicle Air Conditioning System

In order to carry out A/C system recharging operations you are required to connect the device to the vehicle.

Proceed as follows:

1. Place the device near the A/C system you wish to check.
2. Connect the service tubes to the vehicle A/C system.

### 12.2 Visual Warnings

The control panel/display on the device has a series of LEDs that provide information on the status of the device and on the phase in progress at a specific time.

Name Symbol	Colour	Indicates	Blink Code
UPG	Green	Update	<b>Flashing:</b> software update in progress. <b>Off:</b> no activity in progress
BLUE	Blue	Bluetooth communication	<b>Flashing:</b> Bluetooth communication in progress. <b>Off:</b> no activity in progress

### 12.3 Audible Warnings

The control panel/display on the device has an electronic buzzer.

The operator is informed of any errors or warnings regarding the service, not only via messages that appear on the display, but also via a "beep".

### 12.4 CO<sub>2</sub> alarm

The R744 (carbon dioxide, CO<sub>2</sub>) refrigerant of the A/C system is released directly into the air, constantly checking the degree of concentration of carbon dioxide (CO<sub>2</sub>) in the workspace thanks to a specific sensor.

Through both visible and audible indications, the equipment warns that an excessive level of concentration of carbon dioxide (CO<sub>2</sub>) has been reached and automatically interrupts the activity in progress.

Level of concentration of carbon dioxide (CO2)	Warning by the equipment
Standard	No warning
Close to allowed limit (in the workspace).	Display message
Above the allowed limit (in the workspace).	Display message. Audible warning through a buzzer.

If the level of concentration exceeds the allowed limit, the discharge phase is automatically interrupted.

Proceed as follows:





1. *Move away from the equipment.*
2. *Aerate the workspace for the time needed in order to bring the level of concentration of carbon dioxide (CO2) back within the safety level.*

The discharge of the refrigerant resumes normally once the alarm has ceased, when the level of carbon dioxide (CO2) has returned to normal.

## 12.5 How to Use the Software

The software installed in the **KONFORT 744** charging stations allows you to launch all the functions needed for recharging and checking the vehicle's A/C system.

The keypad on the top panel of the device acts as an operator-machine interface and allows you to select and launch the functions available, enter specific data for the operation that needs to be carried out and, in general, allows you to complete all the operations the software permits.

Key	Name	Function
	ENTER	Allows you to confirm the selection made.
	DELETE	Allows you to delete data that has been entered.
	STOP/BACK/CANCEL	Allows you to instantly stop the phase in progress or go back to the previous menu.
	INFO	Allows you to view specific additional information regarding the menu selected.
	UP/DOWN ARROW	Allows you to scroll the options within a menu.

	<p>NUMERIC KEYPAD</p>	<p>These keys allow you to enter the alphanumeric values required to carry out the recharging operations and data related to the client and the company.</p>
---	-----------------------	--



The software provides on-screen instructions to help the operator to carry out the various operations and warns the operator if any error occurs during the individual phases.

## 12.6 Printer

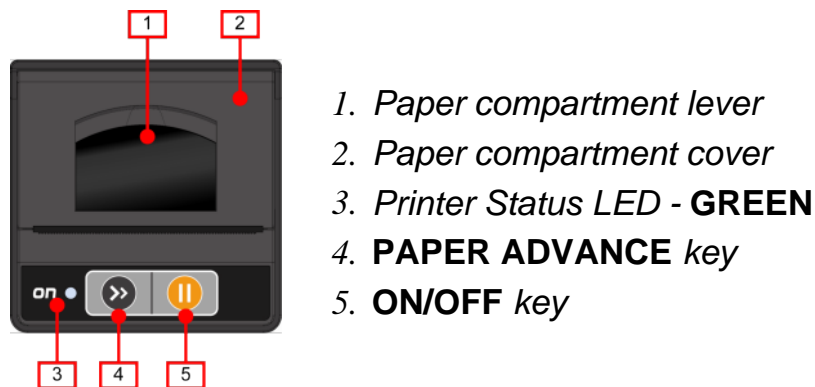
The thermal printer is available on the **744** recharging stations.



The keys on the printer have the following functions:

Key	Name	Function
	PAPER ADVANCE	Allows the paper to come out.
	ON/OFF	Allows the printer to go into on-line/off-line mode.

The printer is equipped with a green LED that indicates its status. The states may be as follows:

- **Fixed on:** *printer on-line*
- **Flashing:** *the printer is off-line or there is no paper in the printer.*
- **OFF:** *printer off-line*

The printer is automatically on-line upon equipment startup.

Press  if the status LED indicates that the printer is off-line.

Using the printer the operator may print a report containing the following information:

- *company data*
- *vehicle data*
- *client data*
- *operations carried out*

The data relative to the company, vehicle and the client can be entered using the numeric keypad.

**For further information consult the software's Operating Manual.**

## 13 STOP

This chapter describes the operations required in order to stop the equipment.



**Do not switch off the equipment by disconnecting the power cable from the socket.**



**Before switching off the equipment, using the specific pressure gauges, make sure the service pipes are not under pressure and eventually depressurise them through the specific software function.**

### *13.1 Normal Stop*

To stop the equipment, set the main switch to the **O** (OFF) position.

### *13.2 Emergency Stop*

To switch off the charging station immediately in case of emergency, press the emergency button located on the equipment's control panel.

Unlock the button by turning it slightly clockwise to remove the emergency lock once the conditions for operating in safety are restored.

### *13.3 Stopping the Equipment for Long Periods*

Should you intend to stop the equipment for a long period of time, follow the instructions below.

Proceed as follows:

- 1. Close the external tank's valve.*
- 2. Depressurise the pipes through the specific software function.*
- 3. Disconnect the equipment from the power mains.*
- 4. Disconnect and store the external tank as indicated in the specific safety sheet.*
- 5. Place the cover provided over the device.*
- 6. Put the device in a safe place, not exposed to outside weather conditions.*

## 14 UPDATING

This chapter describes the operations needed to update the equipment's operating system.

The update takes place through the **SDCARD**.



**You must have a PC with a USB port and an active Internet connection available.**

Proceed as follows:

1. Turn off the device.
2. Locate the **SD CARD** slot.
3. Gently press on the **SD CARD** to unlock it.
4. Remove the **SD CARD**.
5. Enter the **SD CARD** into the **SD CARD READER**.
6. Connect the **SD CARD READER** to a PC.

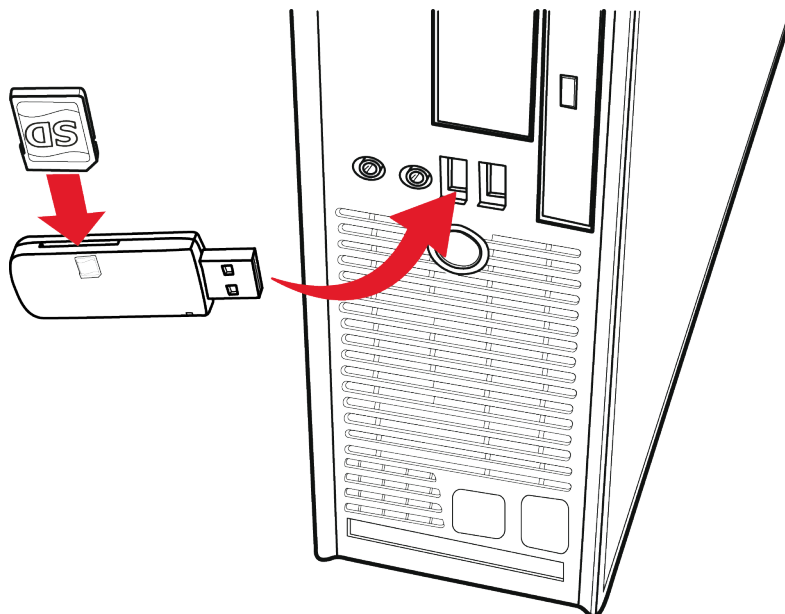

7. Copy the update into the **SD CARD**.
8. Remove the **SD CARD** from the **SD CARD READER**.
9. Enter the **SD CARD** into the appropriate slot on the device.
10. Turn on the device.

The update starts automatically.



**During the update, the display will remain off and the green LED on the top will flash intermittently.**

11. Wait for the update to complete.

12. Once the update is complete, the software restarts automatically.

## 15 MAINTENANCE AND CLEANING

This chapter describes the maintenance operations required for the device.



**Any maintenance operation on the equipment must be carried out only by personnel authorised by TEXA S.p.A.**



**Carefully follow the instructions provided in this manual.**



**Only use original spare parts or approved by TEXA S.p.A.**

For more information contact the post-sales assistance service.

### 15.1 Ordinary Maintenance

Scheduled maintenance is made up of a series of operations that must be carried out periodically.

Specific messages will appear on your display each time a maintenance operation has expired and needs to be carried out.

Maintenance operation	Frequency
Vacuum pump oil replacement	When prompted by the device.
Printer Paper Replacement	each time the paper runs out.



**The maintenance operations that require you to remove parts of the equipment must be carried out with the charging station switched off.**

In order to carry out the charging station maintenance operations described above, you must remove the front shield.

Proceed as follows:

1. *Turn off the equipment.*
2. *Go behind the device.*
3. *Block the rear wheels.*
4. *Using a n° 3 hexagonal wrench remove the four screws that fasten the front cover to the body of the machine.*
5. *Stand in front of the recharging station.*
6. *Using a n° 3 hexagonal wrench loosen the two screws that fasten the front cover to the top cover.*
7. *Lift the top cover slightly.*

8. Remove the front cover.

### 15.1.1 How to Replace the Vacuum Pump Oil

The oil in the vacuum pump must be replaced **when you are prompted to do so by the device.**



**You must carefully read and understand this Operating Manual in order to perform the provided instructions correctly.**

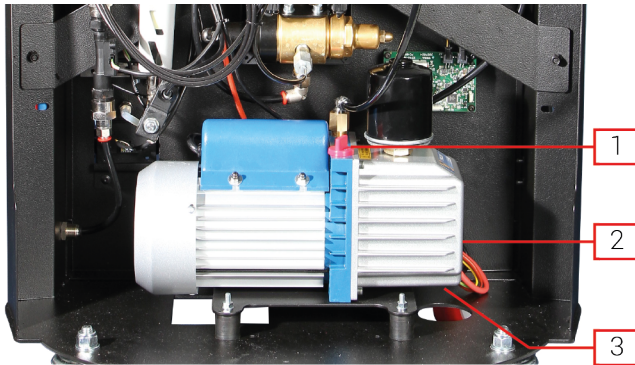

1. Filler cap
2. Pump oil level inspection
3. Oil drain cap

Proceed as follows:

1. Disconnect the device from the power mains.
2. Unscrew the oil drain cap.
3. Wait for all the oil to drain from the pump.



**Collect the recovered oil and dispose of it according to the regulations in force.**

4. Screw the oil drain cap on.
5. Unscrew the oil filler cap.
6. Fill with new oil.



**The correct pump oil level is approximately half of the level warning light and the total amount to refill is approximately 370 ml.**

7. Screw the oil filler cap on.
8. Reset the **Pump Time Counter Reset.**

### 15.1.2 Replacing the Paper in the Printer

Follow the instructions provided in the chapter **Replacing the Paper in the Printer.**

## 15.2 Periodical Checks

In order to guarantee a correct operation of the device we recommend you check the parts that are the most subject to wear on a regular basis.

PART SUBJECT TO WEAR	CHECK
<b>Service hoses</b>	Make sure there are no cuts, scratches or bulges.
<b>Quick fittings</b>	<p>Make sure there are no signs of wear and that the hoses do not harden during use.</p> <p>Make sure the service hoses are connected properly.</p> <p>Make sure there are no cuts or scratches on the O-rings.</p>
<b>Oil and UV bottles</b>	Make sure they are clear and not damaged.
<b>Wheels</b>	Make sure the brakes are working properly.
<b>Power supply cable</b>	Make sure there are not any cuts, abrasions, burns, compressions.
<b>Band heater</b>	Make sure there are not any cuts, abrasions, burns, compressions.
<b>Rear ventilation grille</b>	<p>Make sure it is not obstructed.</p> 

<b>Refrigerant tank coupler O-ring</b>	Check its conditions at every tank change.
--	--

## 16 DISPOSAL

Below you will find information on how to properly dispose of the device.

### *16.1 How to Dispose of the Device*

Take the device to a waste disposal centre.

**For more information regarding the disposal consult the pamplet provided with the device.**

### *16.2 How to Dispose of the Recycled Materials*

The oils removed from the systems must be taken to used oil collection centres.

## 17 TECHNICAL FEATURES

Builder	TEXA S.p.A.
Model	<b>K744</b>
Coolant	R744 (carbon dioxide, CO <sub>2</sub> )
Electronic refrigerant scale (Precise) [g]	± 5
Electronic oil and UV tracer scales (Resolution) [g]	± 1
High pressure gauge [mm]	Ø 80
Low pressure gauge [mm]	Ø 80
TK pressure gauge (external tank) [mm]	Ø 60
Service pipes' length [m]	2,5
Filter assembly	mechanical filter
Vacuum pump	100 l/m, double stage, final pressure 0,03 mbar
Safety device intervention pressure (Rupture discs) [bar]	200 ± 10%
HP pressure sensor [bar]	Rel. 250 Cl. 1.2
LP pressure sensor [bar]	Rel. 160 Cl. 1.2
Tank pressure sensor [bar]	Rel. 250 Cl. 1.2
Vacuum pressure sensor [bar]	Rel. 16 Cl. 2.0
Ambient temperature sensor (Resolution) [°C]	1
Display	TFT 5,7"
SD card memory capacity [GB]	4
Maximum operating pressure [bar]	170
Operation temperature [°C]	10 ÷ 50
Storing temperature [°C]	- 25 ÷ 80
Dimensions [mm]	H: 1100 L: 450 P: 790
Weight [kg]	70

Power supply voltage [V]	230
Frequency (Hz) :	50
Current draw [A]	3,6

# 18 TANK SPECIFICATIONS

We recommend using the charging station with a tank with features in compliance with the indications below.



**Using a tank that is not with the indications below is under the responsibility of the owner of the charging station.**

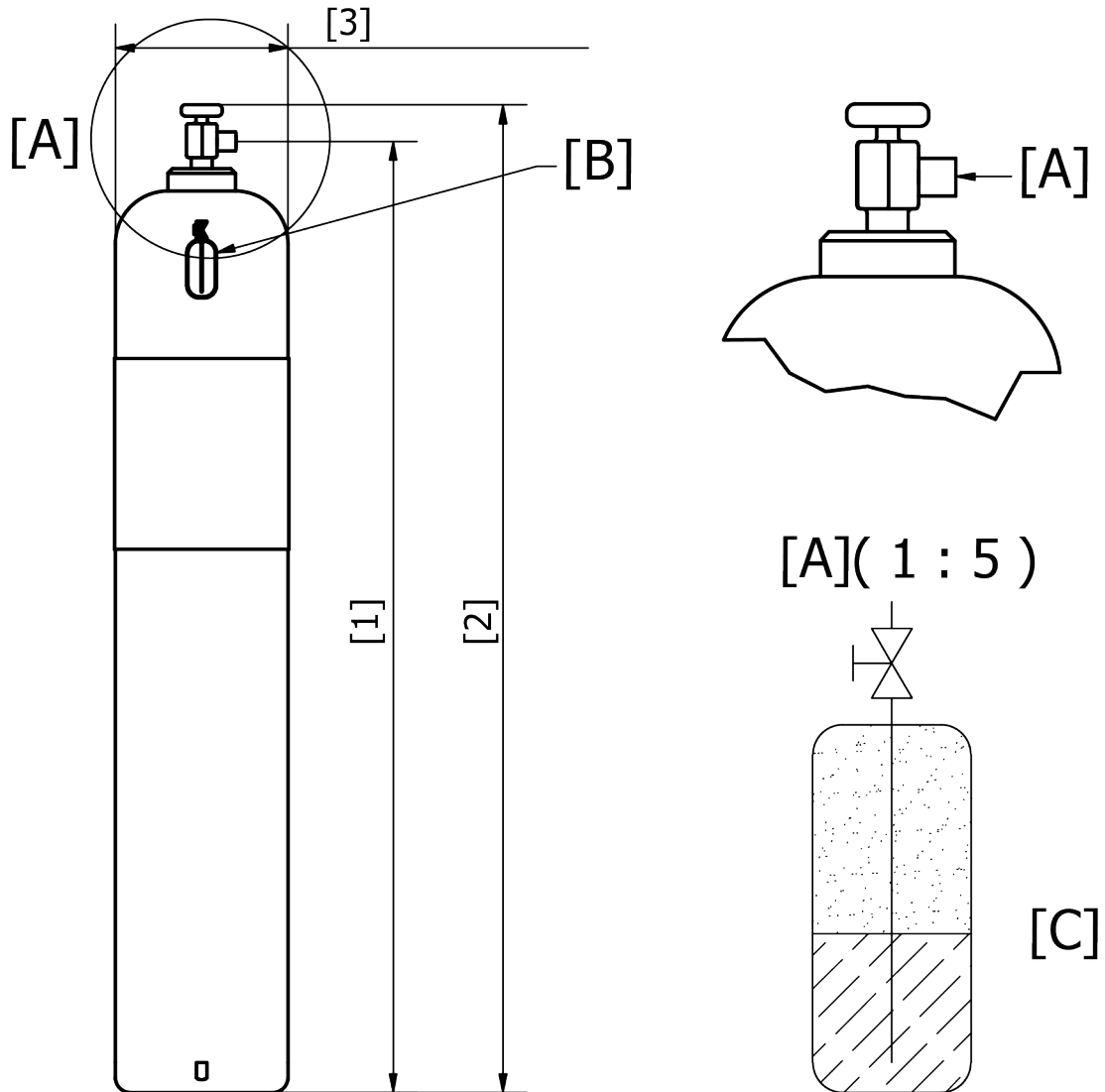

- A) Valve
- B) Pickup pump indication
- C) Liquid discharge with pickup pump

Overall height [2]	890 ± 30 mm
Valve height [1]	840 ± 30 mm
Tank diameter [3]	170 ± 10 mm
Tare weight	18 ± 1 kg
Capacity *	10 ± 1 kg

Material	Steel or light-weight metal
Operating pressure	150 bar min.
Operating temperature	- 10 ÷ 60 °C
Fluid / purity	R744 / 3.0
Reference regulations / specifications for the valve [A]	Designed for UNI 11144-2, it can work with DIN 477-6
Discharge *	From liquid state (pickup pump)

*(\*) Only for liquid refrigerant.*

## 19 LEGAL NOTICES

### TEXA S.p.A.

Via 1 Maggio, 9 - 31050 Monastier di Treviso - ITALY

Tax Code - Company Register of Treviso ID No. - VAT No.: 02413550266

Single-shareholder company subject to the direction and coordination activities of Opera Holding S.r.l.

Paid-up share capital 1,000,000 €- R.E.A. (Economic Administrative Index) No. 208102

Legal Representative Bruno Vianello

Phone +39 0422.791.311

Fax +39 0422.791.300

[www.texa.com](http://www.texa.com)

For information regarding the legal notices, please refer to the **International Warranty Booklet** provided with the product.